

DC – AC Inverters

WP91652

Tyco Electronics Inverters offer a compact, reliable, efficient, and cost-effective power solution for ac-powered equipment, especially in applications subject to adverse grid conditions. The inverters require a –48 Vdc input derived from a –48 Vdc battery plant and provide single phase ac output power.



Features

- Compact size*
- Modular design*
- Front access*
- User-selectable output voltages
- User-selectable frequencies, 50 Hz or 60 Hz
- Static transfer switch (optional on some models)
- Local and remote operation and alarm contacts
- Optional office alarm interface
- Cascade redundant configurable

*Selected models

Benefits

- Economical Operation
 - Models with a static transfer switch provide considerable savings in operating costs due to high operating efficiency.
- High Reliability
 - High mean-time-between-failure (MTBF) ensures an extended service life.
- Versatile Operation
 - User-selectable output voltages allow for greater system flexibility.
 - Inverter operates at frequencies of 50 Hz or 60 Hz for domestic and international applications.
- Space Savings
 - 0.5 kVA and 1 kVA units are 2U high.
 - All units mount in 19, 23, or 25-inch rack widths.

Flexible Performance

Models are available with user-selectable ac output voltages and can operate at frequencies of 50 Hz or 60 Hz.

Variable Inputs/Operating Modes

Models are available with or without a static transfer switch. Units equipped with a transfer switch can operate from either a dc input or from a commercial

ac input source. When an ac source is used, the inverter operates off-line. In this mode, the inverter continuously samples the ac input for line irregularities. When the unit detects that the ac input voltage has dropped below the required limits, a transfer is automatically initiated to the on-line mode within two to four milliseconds.

In the on-line mode, the inverter operates from the dc input source (rectifier or battery). Inverters equipped with a static transfer switch allow the user to manually select operation in either mode.

Units without a static transfer switch operate on-line only.

Schematic Diagrams

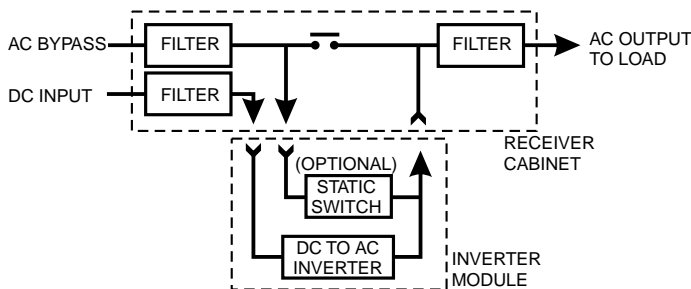

Figure 1. Single-line diagram with optional static switch option

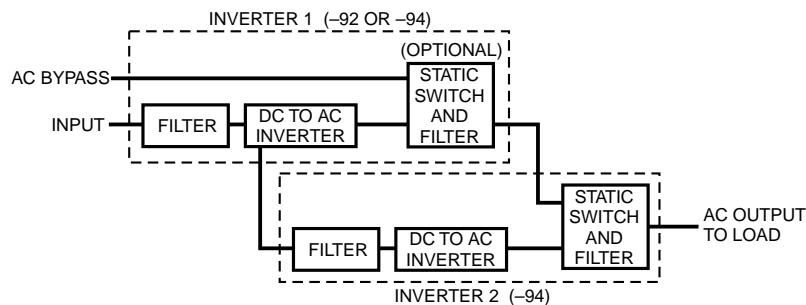

Figure 2. Cascade redundant configuration option

Cascade redundant operation (optional). Standby inverter 1 is on-line at all times, drawing no load current. Its load is the bypass of primary inverter 2. Failure of the primary inverter automatically transfers load via static switch to the standby inverter. In the unlikely event of a failure on the standby inverter, the load automatically transfers (via the standby static switch) to the ac bypass line input. (Note: Output power to the load is limited to the power rating of bypass inverter 2. The WP91652 is not intended for parallel operation to achieve increased capacity.)

Specifications

	500 VA, 1 kVA	3 kVA, 5 kVA, 10 kVA	Plant Configuration¹ 5 kVA, 10 kVA
Technologies	Isolated boost converter/ Dual PWM inverter	High frequency PWM inverter	High frequency PWM inverter
Input			
Input Voltage	-40 to -60 Vdc (500 VA and 1 kVA)	-42 to -56 Vdc	-42 to -56 Vdc
DC Input Filtering	< 30 dBrnC	< 32 dBrnC	< 32 dBrnC
DC Input Protection	30A internal circuit breaker (500 VA and 1 kVA)	100A internal circuit breaker (3 kVA) 175A internal circuit breaker (5 kVA) 350A internal circuit breaker (10 kVA)	175A internal circuit breaker (5 kVA) 350A internal circuit breaker (10 kVA)
Output			
Power Rating	500 VA/420 W 1 kVA/840 W	3 kVA/2520W 5 kVA/4200 W 10 kVA/8400 W	5 kVA/4200 W 10 kVA/8400 W
Output Voltage	100/110/115/120/220/ 230/240 Vac (selectable)	120/220/230/240 Vac (selectable)	120/220/230/240 Vac (selectable)
Frequency	50/60 Hz (selectable)	50/60 Hz (selectable)	50/60 Hz (selectable)
Frequency (Stability)	± 0.02% maximum	± 0.02% maximum	± 0.02% maximum
Load Regulation	±1% maximum for load variations between no load and full load at nominal line	±2% maximum for load variations between no load and full load at nominal line	±2% maximum for load variations between no load and full load at nominal dc input
Power Factor	0.6 leading or lagging	0.7 leading or lagging	0.7 leading or lagging
Total Harmonic Distortion	2% max for linear load <3% for non-linear load from 0% to 100% load	<5% for all linear load conditions	5% for all linear load conditions
Crest Factor	3:1	3:1	3:1
Efficiency	85% typical (97% off-line)	85% minimum (97% off-line)	85% minimum (97% off-line)
Overload Capability	150% for 30 seconds 125% continuous (500 VA & 1 kVA)	200% 10 seconds 300% 1 cycle	200% 10 seconds 300% 1 cycle
Transfer Time	< 2 ms	4 ms typical	4 ms typical
Output Wave Form	Sinewave	Sinewave	Sinewave
Indicators and Controls			
Meters	Digital LCD (Liquid Crystal Display) displays two lines of twenty characters	Digital, vacuum fluorescent readout	Digital, vacuum fluorescent readout
LEDs	Front panel indicators	Front panel indicators	Front panel indicators
Environmental			
Operating Temperature Range	-10 to +50°C (0.5 and 1 kVA)	-10 to +50°C (3 kVA) 0 to +45°C (5 and 10 kVA)	0 to +45°C
Storage Temperature	-40 to +75°C	-40 to +75°C	-40 to +75°C
Relative Humidity	0%—90% relative, without condensation	0%—95% relative, without condensation	0%—95% relative, without condensation
Operating Altitude	Up to 10,000 ft.	Up to 10,000 ft. (3 kVA) -200 ft. to +10,000 ft. (5 kVA and 10 kVA)	-200 ft. to +10,000 ft.
Audible Noise	<55 dBA at 4 ft. (500 VA and 1 kVA)	<65 dBA at 4 ft.	<65 dBA at 4 ft.
Heat Rejection	500 VA = 315 BTU/hr. 1 kVA = 587 BTU/hr.	3 kVA = 1265 BTU/hr. 5 kVA = 4200 BTU/hr. 10 kVA = 8500 BTU/hr.	5 kVA = 4200 BTU/hr. 10 kVA = 8500 BTU/hr.

Specifications (continued)

Standards

Agency Certifications	<i>UL</i> * 1012, <i>C-UL</i> , TUV, CE, FCC Part 15, Class A	<i>UL</i> 1012, FCC Part 15, Class A, Part B requirements	<i>UL</i> 1012, FCC Part 15, Class A, Part B requirements
-----------------------	---	---	---

1. KS24007 Inverter "Plant Configuration" consists of a 23-inch equipment rack, an inverter (rated 5 or 10 kVA), a maintenance bypass switch, an ac distribution panel, and cables/conduits kit. (Inverter is shipped separately.) (Order circuit breakers separately.)

**UL* is a registered trademark of Underwriters Laboratories, Inc.

Inverter Features and Capabilities by Model

	500 VA	1 kVA	3 kVA	5 kVA	10 kVA	Inverter Plant (KS24007) ^{2,3}
Corresponding List Numbers ¹	14, 15	22, 23	40A, 41A	52	62	3, 4
Dimensions (H x W x D) (in.)	3.5 x 17 x 19	3.5 x 17 x 19	17.5 x 17 x 15.3	24.5 x 17 x 15.3	42 x 17 x 24.3	Refer to 5 kVA and 10 kVA
Approx. Weight	34 lb. (15.4 kg)	34 lb. (15.4 kg)	170 lb. (77 kg)	230 lb. (104 kg)	440 lb. (200 kg)	5 kVA: 384 lb. (174 kg) 10 kVA: 594 lb. (269 kg)
BTU/Hour	360	715	2250	4200	8500	4200 (L-3) 8500 (L-4)
Field-Selectable Frequency and Voltages	X	X	X	X	X	X
Selectable On-line/Off-line Mode with Static Switch	X	X	X	X	X	X
Overvoltage Protection	X	X	X	X	X	X
High Efficiency	X	X	X	X	X	X
Cascade Redundant Configurable	X	X	X	X	X	X
High Switching Frequency	X	X				
Modular	X	X				
Advance Microprocessor Controller with Status Monitoring	X	X				
Digital Display (Volts, Amperes)			X	X	X	X
Easy Installation (With Lifting Eyes)			X	X	X	X
Simple Maintenance	X	X	X	X	X	X
Wrap Around Maintenance Bypass Option						X
Office Alarm Option						X ³
Hot Swappable Capability	X	X				
Rack Mountable	X	X	X	X	X	
Floor Mountable				X	X	X

1. Even list number models include a static transfer switch. Odd list number models do not include static switch.

2. KS24007 inverter plant model comes with an inverter (5 kVA or 10 kVA), a maintenance bypass, and an ac distribution panel.

3. Optional WP93599 inverter alarm panel provides office alarm interface.

Outline Drawings

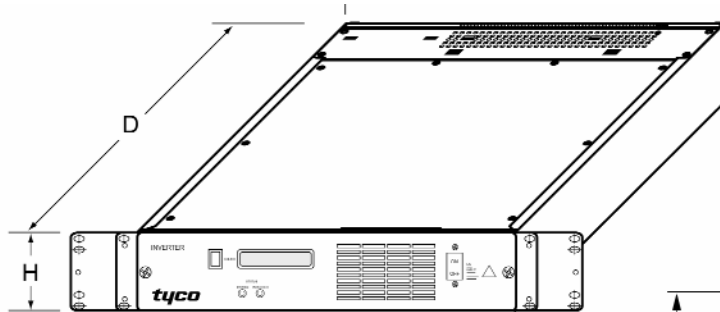

Rack-Mounted Inverter WP91652
500 VA, L14, L15
1 kVA, L22, L23

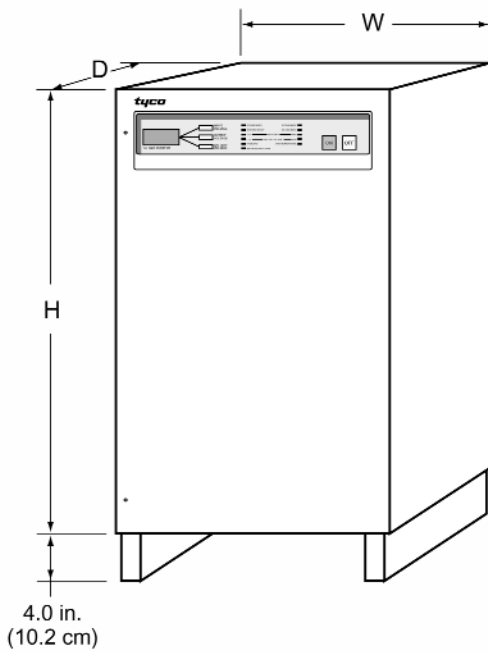

Floor-Mounted Inverter WP91652
5 kVA, L52
10 kVA, L62

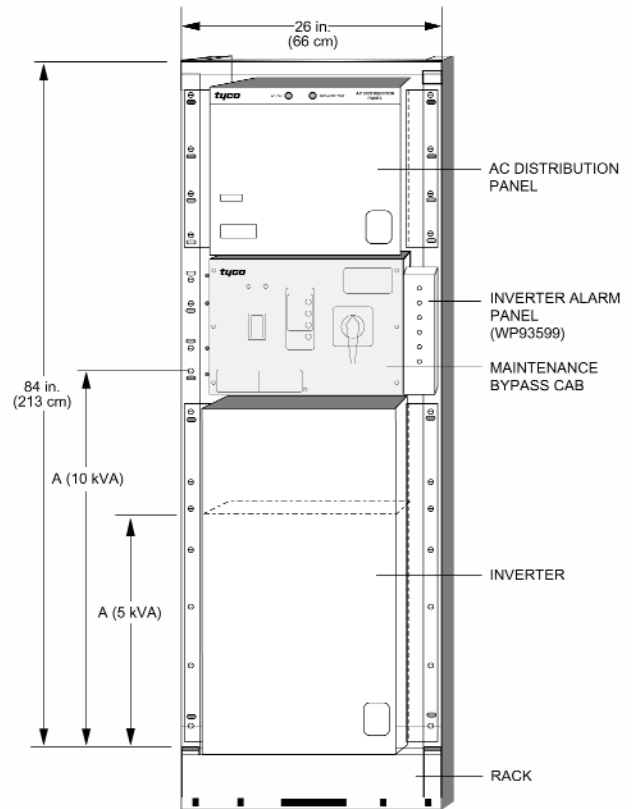

Inverter Plant KS24007
5 kVA, L3
10 kVA, L4

Physical Characteristics

Rating	500 VA	1 kVA	3 kVA	5 kVA	10 kVA
List No.	L14, L15	L22, L23	L40A, L41A	L52	L62
Dimensions inches (cm)	3.5 x 17.0 x 19 (8.9 x 43.2 x 48.3)	3.5 x 17.0 x 19 (8.9 x 43.2 x 48.3)	17.5 x 17.0 x 15.3 (44.5 x 43.2 x 38.9)	24.5 x 17.0 x 18.3 (62.2 x 43.2 x 46.5)	42.0 x 17.0 x 24.3 (106.7 x 43.2 x 61.7)
Approx. Weight	34 lb. (15.4 kg)	34 lb. (15.4 kg)	170 lb. (77.1 kg)	230 lb. (104.3 kg)	440 lb. (199.6 kg)
Heat Rejection (BTU per Hour)	315	587	1265	4200	8500

Note: Even-numbered list numbers (L14, L22, L40, L52, L62) include static transfer switch.
Odd-numbered list numbers (L15, L23, L41) do not include static transfer switch.

Ordering Information

Inverters With Static Transfer Switch

Rating	Comcode	WP91652 List No.	Spare Parts Kit Comcode	WP91652 List No.
500 VA	407604263	L14	407604305	L221
1 kVA	407604289	L22	407604321	L223
3 kVA	407117274	L40A	407154947	L207A
5 kVA	408490779	L52A	406938886	L213
10 kVA	408490761	L62A	406938852	L215

Inverters Without Static Transfer Switch

Rating	Comcode	WP91652 List No.	Spare Parts Kit Comcode	WP91652 List No.
500 VA	407604271	L15	407604313	L222
1 kVA	407604297	L23	407604339	L224
3 kVA	407117829	L41A	407154954	L208A

Optional Inverter Brackets

Description	Use With Inverter Size	Bracket Comcode	WP91652 List No.
Inverter Bracket (19 in./23 in.)	500 VA, 1 kVA	407604370	L117
Inverter Bracket (19 in./23 in.)	3 kVA	405890138	L109
Inverter Bracket (19 in./23 in.)	5 kVA	405890120	L108
Inverter Bracket (19 in./23 in.)	10 kVA	405885351	L107

Inverter Plant

Rating	Description	Comcode	List No.
5 kVA	Inverter plant: includes 23 in. frame with 5 kVA inverter, maintenance bypass switch, ac distribution panel, blank panel assembly, and wired in framework. Inverter is shipped in a separate container.	847313236	KS24007 L3
10 kVA	Inverter plant: includes 23 in. frame with 10 kVA inverter, maintenance bypass switch, ac distribution panel, blank panel assembly, and wired in framework. Inverter is shipped in a separate container.	847313244	KS24007 L4
(5 kVA or 10 kVA)	(Optional) Office alarm interface with audible and LED display for 12 major and minor alarms plus form-C relay outputs	408071967	WP93599 L2



World Wide Headquarters

Tyco Electronics Power Systems, Inc.
3000 Skyline Drive, Mesquite, TX 75149, USA
+1-800-843-1797
power.tycoelectronics.com
email: techsupport1@tycoelectronics.com

Europe, Middle-East and Africa Headquarters

Tyco Electronics (UK) Ltd
Tel: +44 (0) 1344 469 300, Fax: +44 (0) 1344 469 301

Caribbean-Latin America-Brazil Headquarters

Tyco Electronics Power Systems
Tel: +56 2 209 8211, Fax: +56 2 223 1477

Asia-Pacific Headquarters

Tyco Electronics Singapore Pte Ltd
Tel: +65 6416 4283, Fax: +66 6416 4299

India

Tyco Electronics Systems India Pte Ltd
Tel: +91 80 841 1633 x3001

Tyco Electronics Corporation reserves the right to make changes to the product(s) or information contained herein without notice. No liability is assumed as a result of their use or application. No rights under any patent accompany the sale of any such product(s) or information.

©2003 Tyco Electronics Power Systems, Inc., (Mesquite, Texas) All International Rights Reserved.
Printed in U.S.A.

July 2003
DS03-064 Rev 3